

# Yichun Wonsen Intelligent Equipment Co., Ltd.

A decorative graphic on the left side of the slide. It features several interlocking gears in various shades of blue and white. The background is a light blue grid with faint binary code (0s and 1s) scattered throughout. There are also some abstract shapes like circles and triangles.

*Wonsen is committed to build a century-old company up to international leading level.*

# CONTENTS

01

**Company Profile**

02

**R&D and Production**

03

**Products and Markets**

04

**Development Plan**





01

## Company Profile



# Company profile

---



**Wonsen** was founded in September 2010, a state-level high-tech enterprise, specializing in the R&D, manufacturing and sales of Pharmaceutical & Food equipment, and also Software service. We provide complete solutions including single machine, automated production line and digital factory project. Driven by a corporate philosophy of Innovation, Wonsen is committed to build a century-old company up to international leading level.



# Company profile



## **Wonsen Group:**

**Yichun Wonsen Intelligent Equipment Co., Ltd. (OSD equipment)**

**Yichun Wonsen Information Technology Co., Ltd. (Information system, such as SCADA)**

**Jiangxi Wanshen Machinery Co., Ltd. (Packing equipment)**

# Company profile

- Factory area of **93000m<sup>2</sup>**, construction area of nearly **60000m<sup>2</sup>**
- **400+ staffs**
- Technical team of **72** people, including 11 masters ,3 doctors, 6 people of senior professional title, and 1 provincial academic leader.
- 370 sets of processing equipment
- 3 provincial-level R&D platforms such as the Solid Equipment Technology Research Center
- **2000m<sup>2</sup>** of laboratories, more than 20 million experimental equipment and testing instruments
- Strategic cooperation with Zhejiang University, Nanchang University, Jiangxi University of Traditional Chinese Medicine, Yichun University, etc
- Undertake 21 national provincial and ministerial science research projects
- Authorized 146 patents, 28 invention patents, and 20 computer software copyrights
- 1100+ customers, and export to 40+ countries





# Chronicle of events

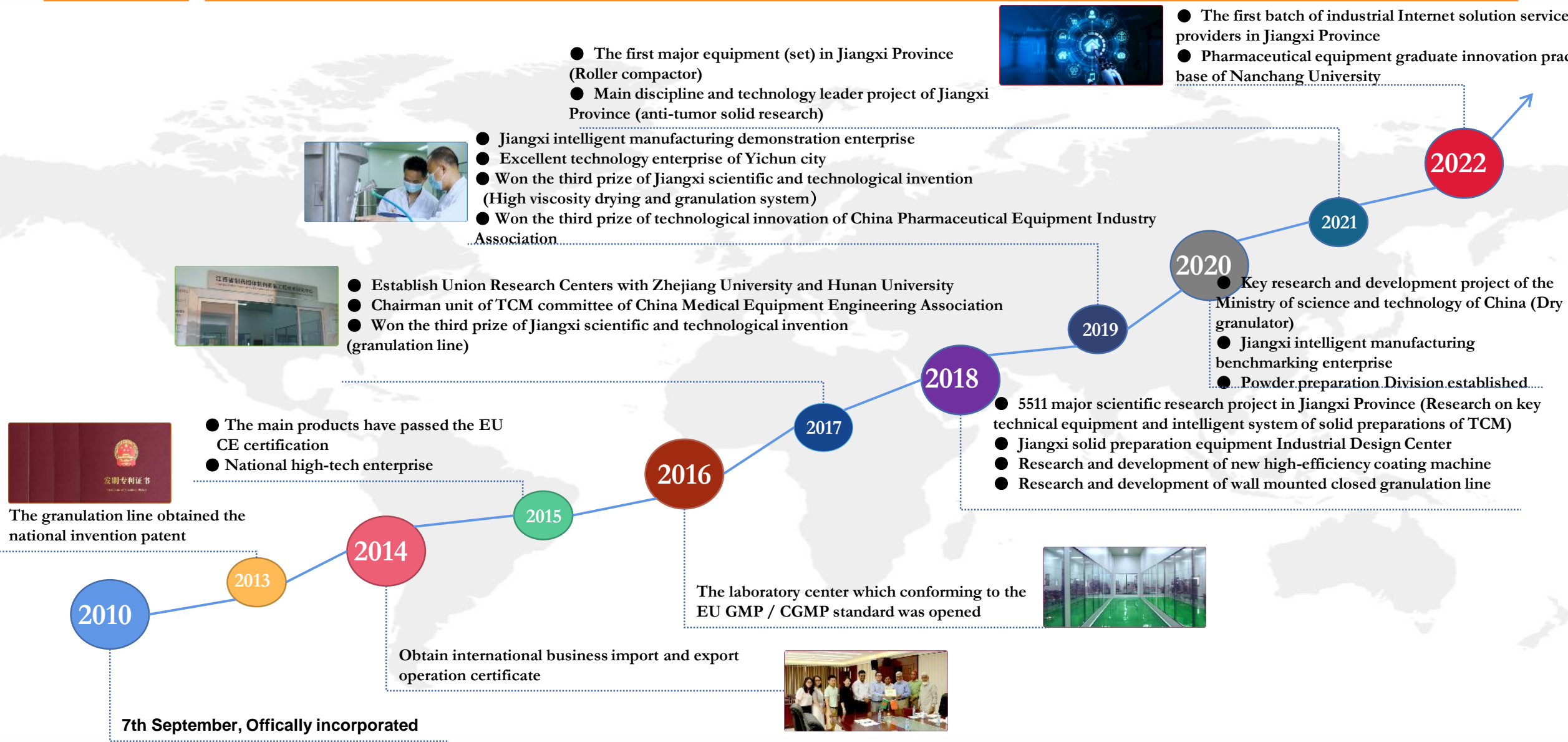

# Organizational chart

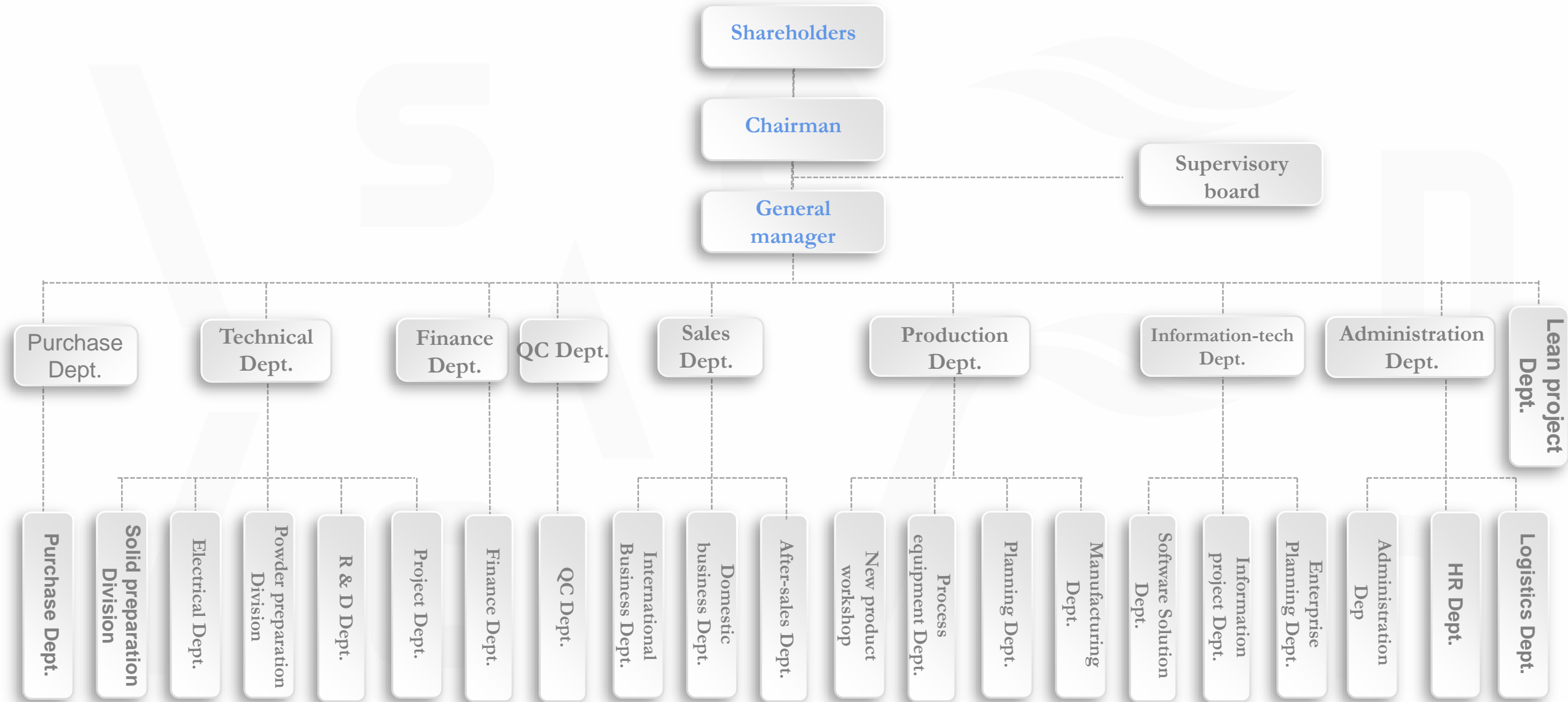



# Honors



- National High-tech Enterprise
- The main products have passed CE certification and TUV certification in North America
- Electromechanical installation general contracting qualification level III
- The "Small Giant" Enterprise of National Professional, Sophisticated, Distinctive, Innovative
- National Major Scientific Research
- Special Undertaking Unit Jiangxi Province Intelligent Manufacturing Benchmarking Enterprise
- Enterprise with 100+ patent applications in Jiangxi Province
- National intellectual property advantage enterprise
- Major R&D special undertaking enterprise
- Technical leaders of main disciplines in Jiangxi Province project undertaking enterprise
- Undertaking enterprises of the first set of major equipment project in Jiangxi Province
- Yichun excellent scientific and technological enterprise
- The first batch of industrial Internet solution service providers in Jiangxi Province

# Honors



- Two scientific and technological invention awards of Jiangxi Province
- Two technological innovation awards of China Pharmaceutical Equipment Industry Association
- Jiangxi Famous Brand Products and etc...



## Social news & events



Two provincial Party Secretaries visited our company for investigation



## Social news & events



The provincial meeting of strong industry was held in our company

## Social news & events



Drug administration and other departments have visited our company  
for research and cooperation



# Enterprise culture

---



## Mission:

To serve the human  
health industry



## Philosophy:

Integrity, Dedication, Pragmatism,  
Innovation



## Vision:

Committed to build a century-old company up  
to international leading level.

# Factory appearance

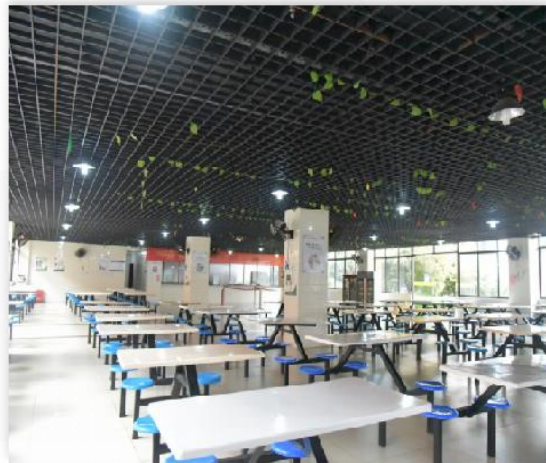



# Versatile staff







02

R&D and Production

# R&D - Scientific Research Platform

## Strong scientific research platform

- Jiangxi Province Solid Preparation Manufacturing Equipment Industrial Design Center
- Jiangxi Pharmaceutical Solid Preparation Equipment Engineering Technology Research Center
- Jiangxi Pharmaceutical Solid Preparation Equipment Engineering Technology Research Center
- **National Key Laboratory of Innovative Drugs and Energy-efficient Pharmaceutical Equipment (cooperation)**

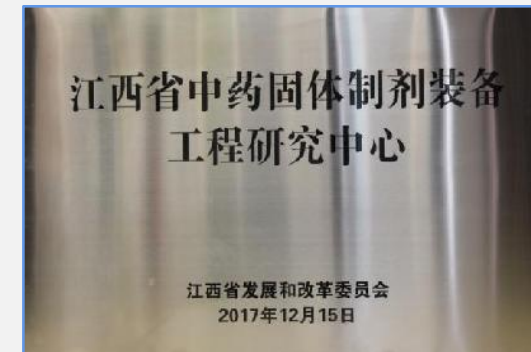
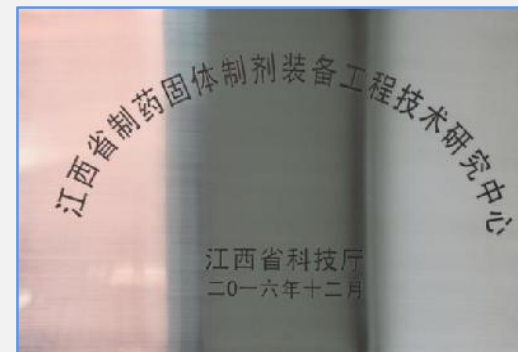
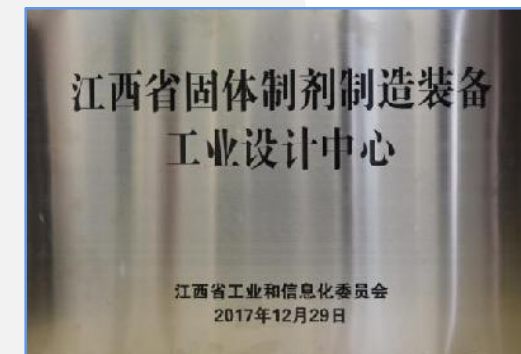

# R&D - University-Enterprise Cooperation

## Cooperation with 5 colleges and universities

- Joint Research Center for Automated Pharmaceutical Equipment of Zhejiang University
- Joint Research Center for Energy-efficient Equipment of Hunan University
- Intelligent Pharmaceutical Equipment Joint Laboratory of Jiangxi University of Traditional Chinese Medicine
- Graduate Training Base of Jiangxi University of Traditional Chinese Medicine
- Nanchang University Pharmaceutical Equipment Graduate Innovation Practice Base
- Yichun University Excellent Engineering Base

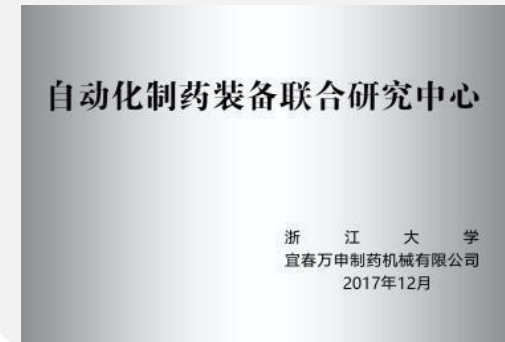
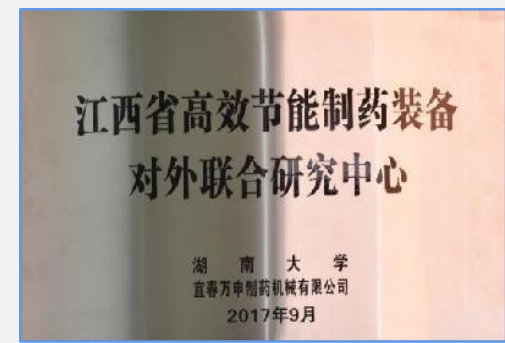
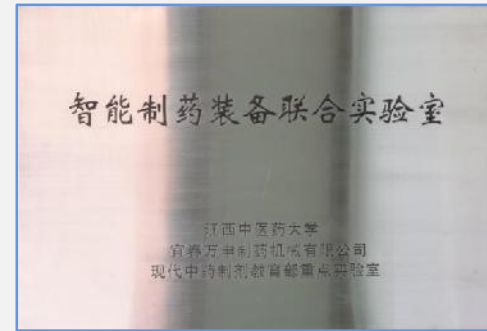



# R&D - Laboratory Center



Nearly 2000 m<sup>2</sup> of small and medium-sized process test center

# R&D - Laboratory Center

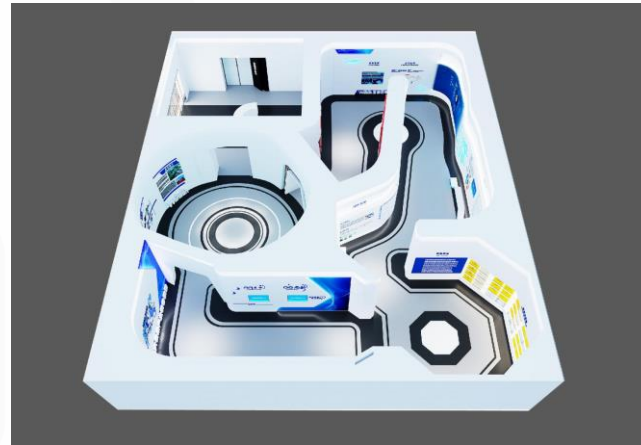

Nearly 2000 m<sup>2</sup> of small and medium-sized process test center

# R&D - Laboratory Center

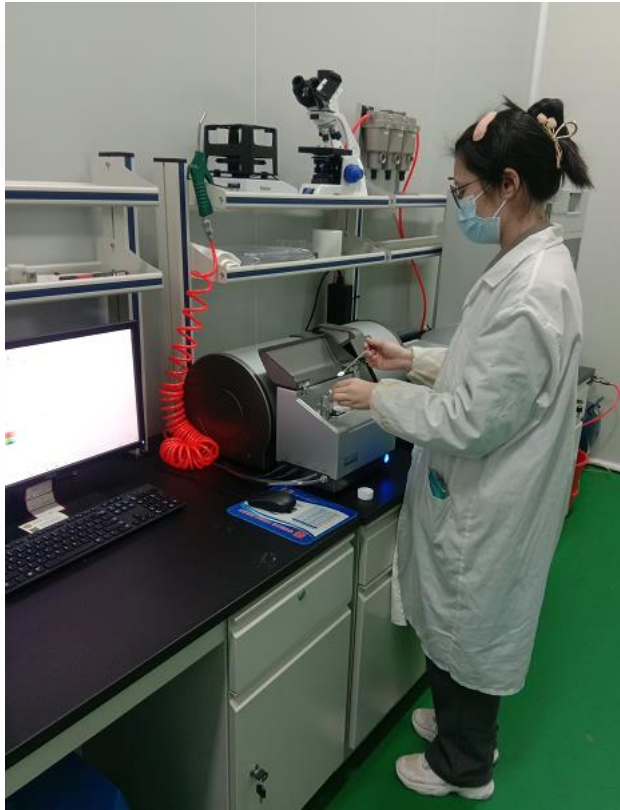

Laser granule size distribution analysis system



Intelligent powder characteristic tester

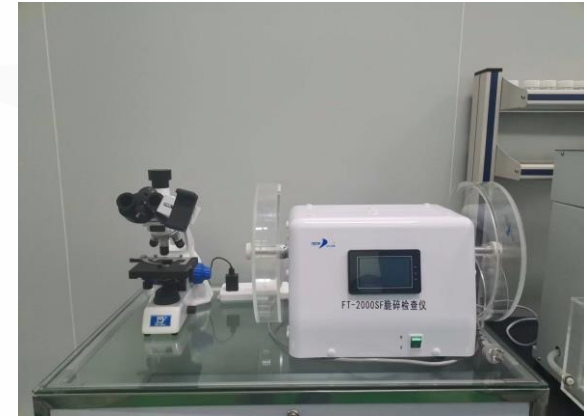

Fragility tester



Intelligent disintegration tester

Advanced testing instruments



# 72 Existing technologists

- Including 3 doctors, 11 masters , 6 people of senior professional title, and 1 provincial academic leader.
- It is a technical team specialized in overall planning, process optimization, simulation analysis, structural design, automatic control, software development, project management, installation training, verification services, etc.

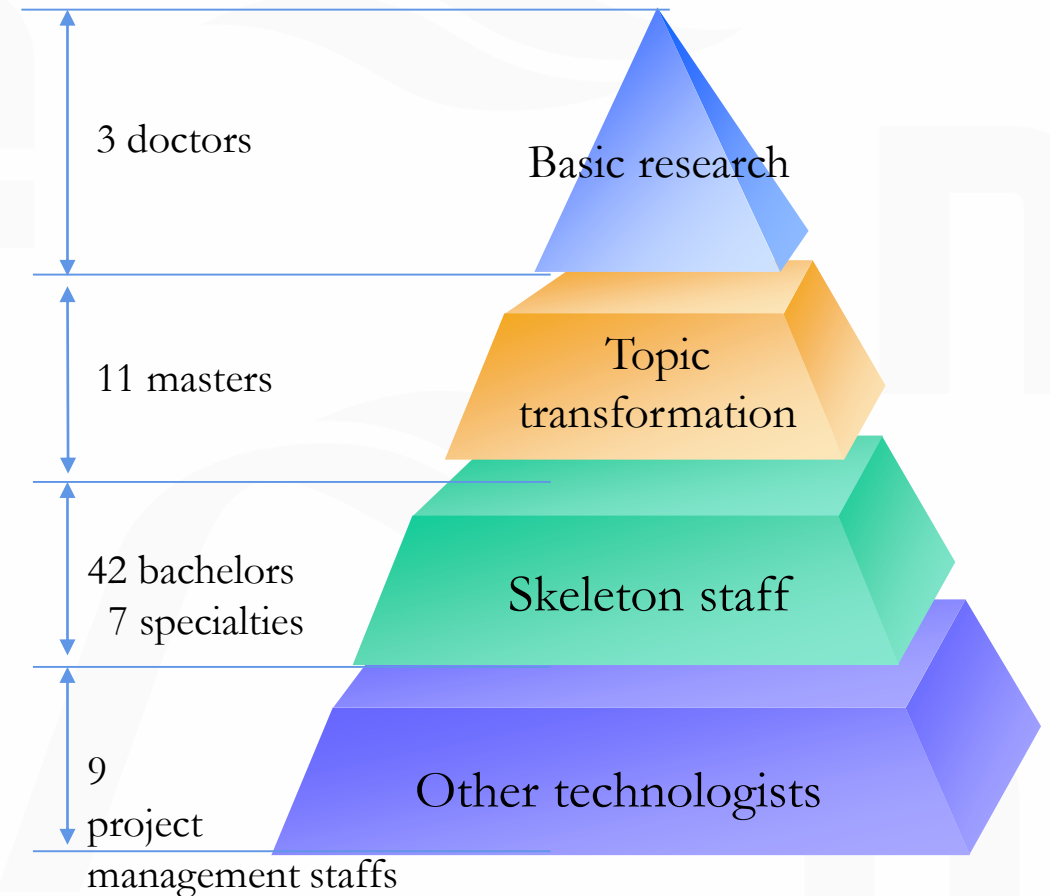

*Ansys simulation technology+Solidworks design software+BIM engineering software*

# R&D - Scientific Research Achievements

Authorized national patents:

Total 146

Including 28 invention patents

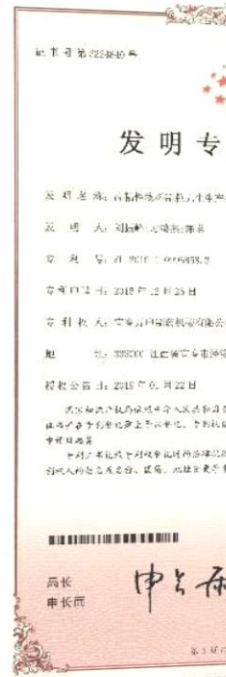
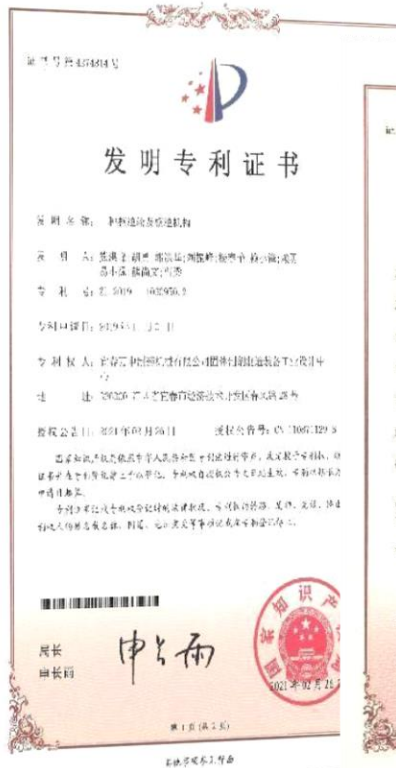
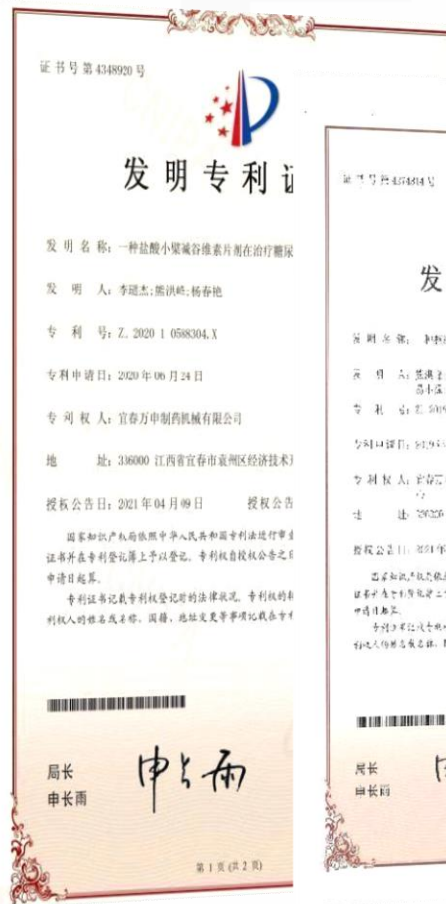
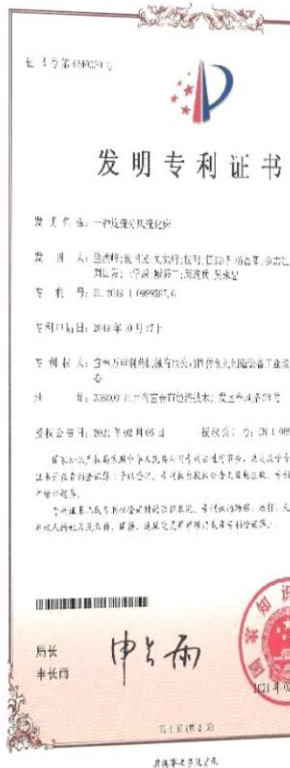
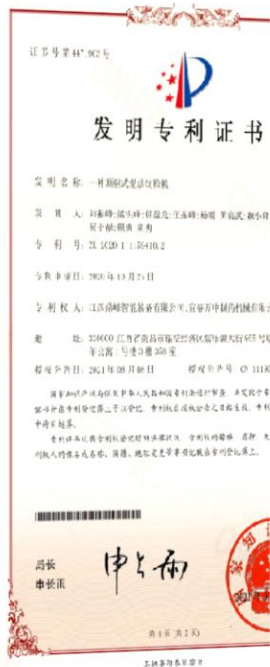
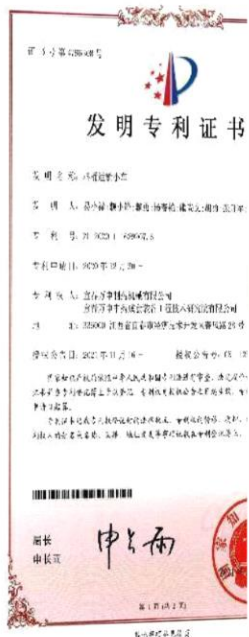



Software works patents:

# Total 20





# Production - Advanced Processing Equipment





# Production - Lean Management (6S)



Visual production site management



# Production - Lean Management (Assembly site)





# Production - Lean Management (Workshop site)





# Production - Digital Management



Realize digital management from order - planning - blanking - metalworking - sheet metal - polishing  
- assembly - delivery - acceptance - service



# Production - Quality Management

**Quality policy:** customer first, quality first, continuous improvement and excellence.



Advanced processing equipment + precision testing instruments + Strict factory inspection + Scientific project management

**ALL Projects were delivered with perfection.**

# Production quality control (precision testing instruments)

可程式声级计
表面粗糙度测量仪
转速仪
X射线荧光光谱仪
温湿度检测仪
数字压力表
风速仪
红外线测温枪
红外线测温枪
手动数显洛氏硬度计
接地电阻测试仪
世达数显扭力扳手
世达数显扭力扳手



X-ray fluorescence spectrometer



Pressure meter



Rotation speed tester



Surface roughness tester



Grounding resistance tester



Thermodetector



Programmable sound level meter



Anemometer





03

Products and Markets

# Products

---

Solid



Powder



Digital



**Product concept:** meet the requirements of technology, dust-free, automation and digitalization



# Products - Production Equipment



Granulation Line



Granulation Line



Dry granulation Series



Auto Lifting Bin Blender Series

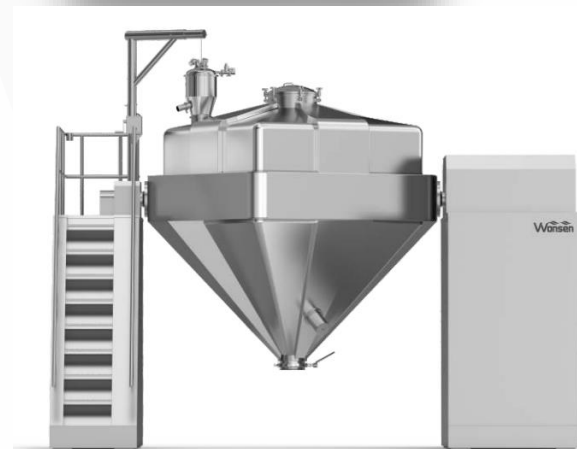

Square Cone Bin Blender Series



Coating Series

# Products - Production Equipment



Single Column Lifting  
Blender Series



Lifting Series



Hammer Mill Series



Cone Mill Series



IBC Bin Series

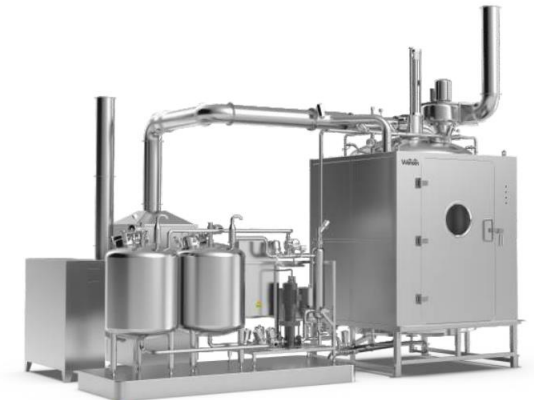

Cleaning Series



# Products - Laboratory Equipment



Lab Rapid Mixer  
Granulator



Lab Multifunctional  
Fluid Bed Granulator



Lab Roller Compactor



Lab Coating  
Machine



Lab Bin Blender



IBC Bin Cleaning  
Machine

# Products - Production Line



Tablet



Capsule



Granule



TCM Granule



# Products - OEB Containment Equipment

Containment level: OEB4 / OEB5



1-5kg  
Containment batching + granulation



10-200kg  
Containment granulation line

# Products - OEB Containment Equipment

Containment level: OEB4 / OEB5



10-200kg  
Containment granulation line

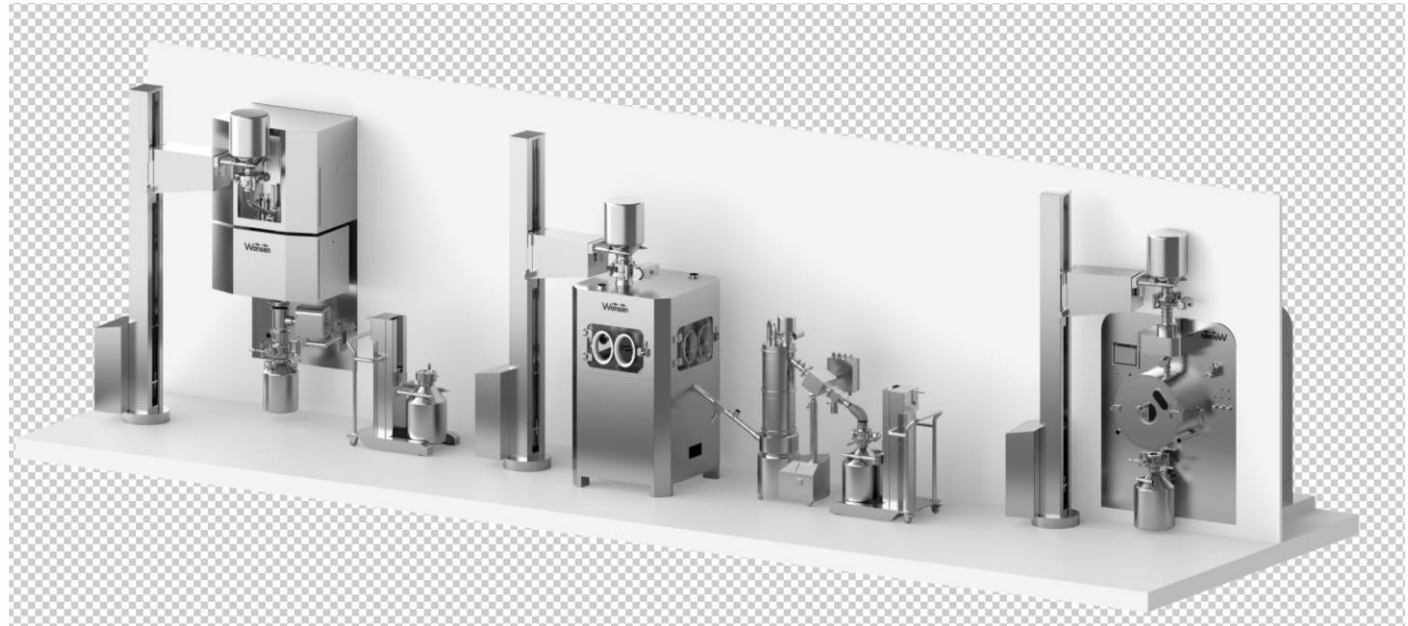

10-200kg  
Containment granulation line



# Products - OEB Containment Equipment

Containment level: OEB4 / OEB5



1-30kg

Containment Roller compactor



60-200kg

Containment Roller compactor

# Products - OEB Containment Equipment

Containment level: OEB4 / OEB5



Coating series



Tableting press series



Capsule filling series



Coating series

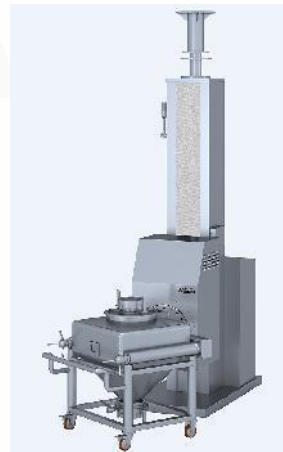

Mixing series



Cleaning series



# Product - Powder automatic production line(semi-automatic)



**Feeding station+Manual assistance**

# Product - Powder automatic production line(dust-free and automatic)

---



**AGV+Robot**



# Products - Digital Solutions



Digital factory



Weak current integration

# Market - Overview

---

Based on China domestic market and  
explore worldwide market

- Served 1100 enterprises
- Export to 41 countries and regions  
around the world
- Offices in 17 countries





# Market - Partial Customers (domestic)



## Market - Cases (domestic)



Bostal drug (OEB4 1-5kg)



# Market - Cases (domestic)

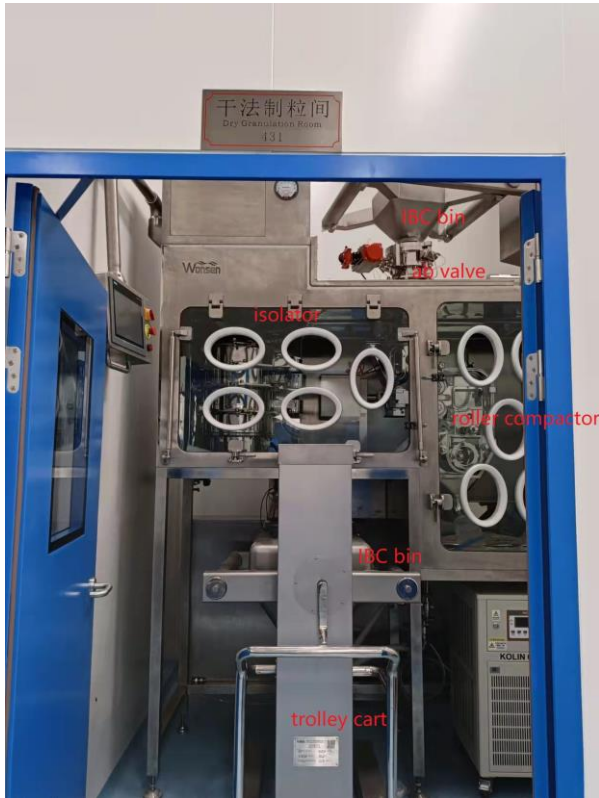

Kinhoo Pharmaceutical (OEB4 30kg)



## Market - Cases (domestic)



Zhejiang CDMO Pharmaceutical Co., LTD (OEB4 60kg)

# Market - Cases (domestic)



Zhongtong  
granulation line



Jemincare  
granulation line



Sinopharm coating  
machine



# Market - Cases (domestic)



Suzhong  
Granulation line



Lukang  
Multifunctional FBD



Wan Shicheng  
Roller compactor



Lukang Coater



Huiren  
Auto lifting blender



NGP Square cone bin  
blender

# Market - Cases (tablet production line)

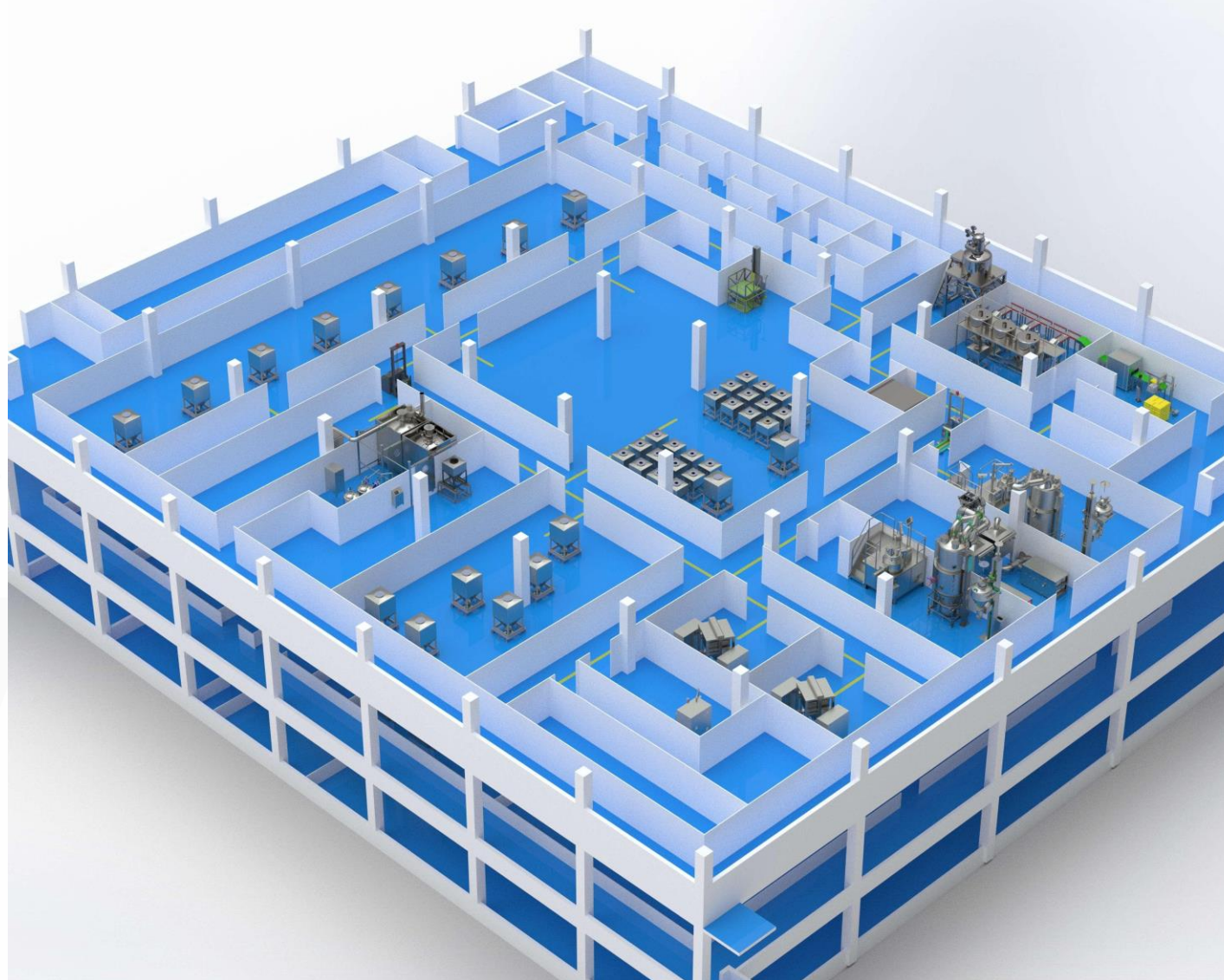

Kinhoo tablet  
production line

# Market - Cases (granule production line)

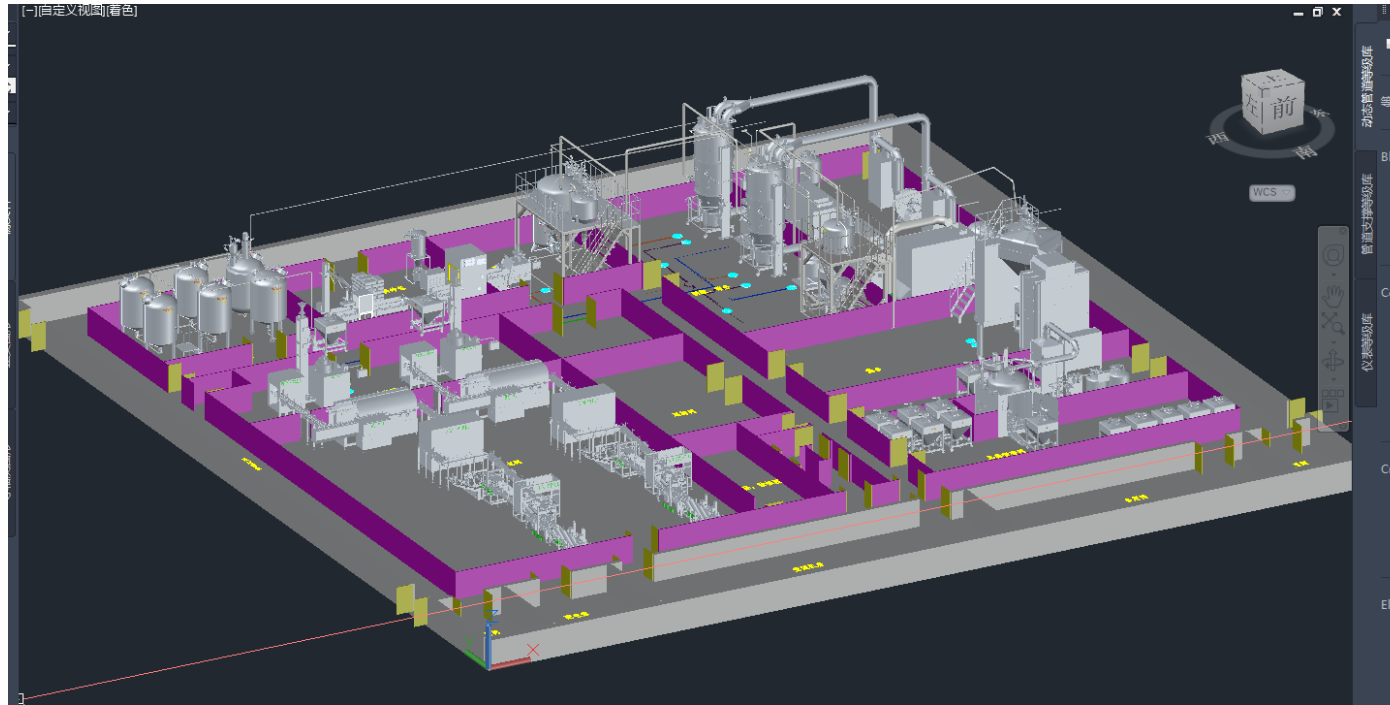

Sinopharm granule production line



# Market - Cases (powder production line)

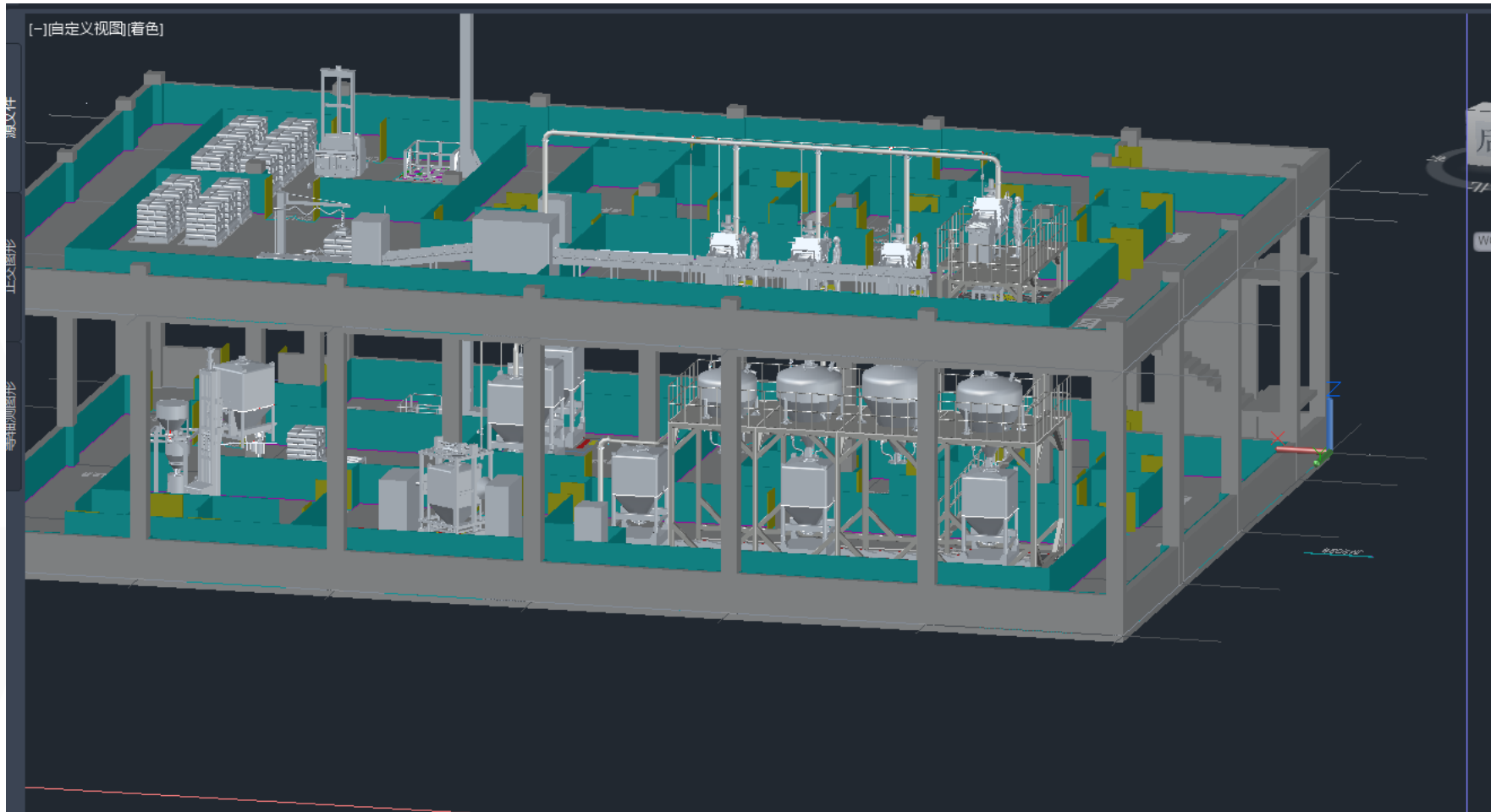

Powder production line

# Market - Cases (domestic powder)



An Qi  
Granule line

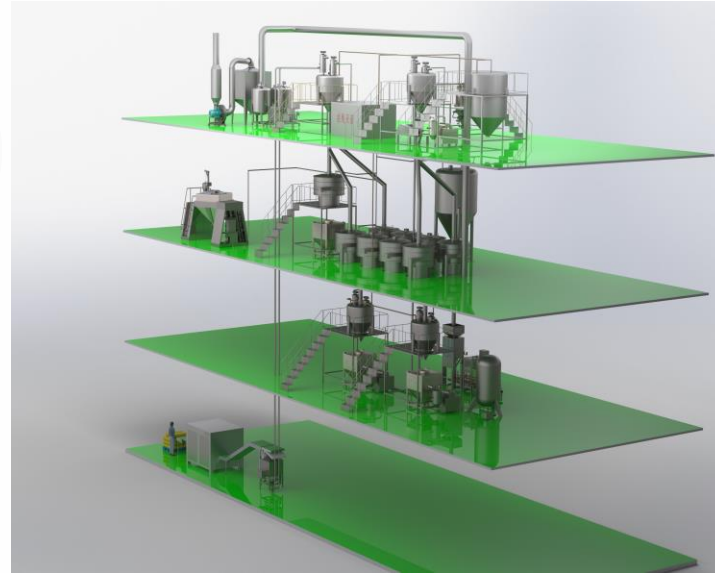

Jia Biyou  
Power line

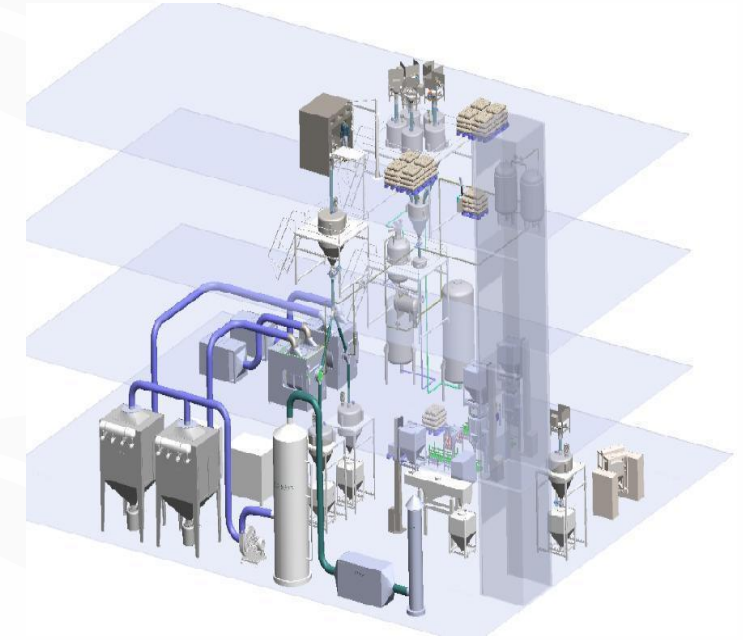

Xin Hua Power line

# Market - Cases (domestic digital)

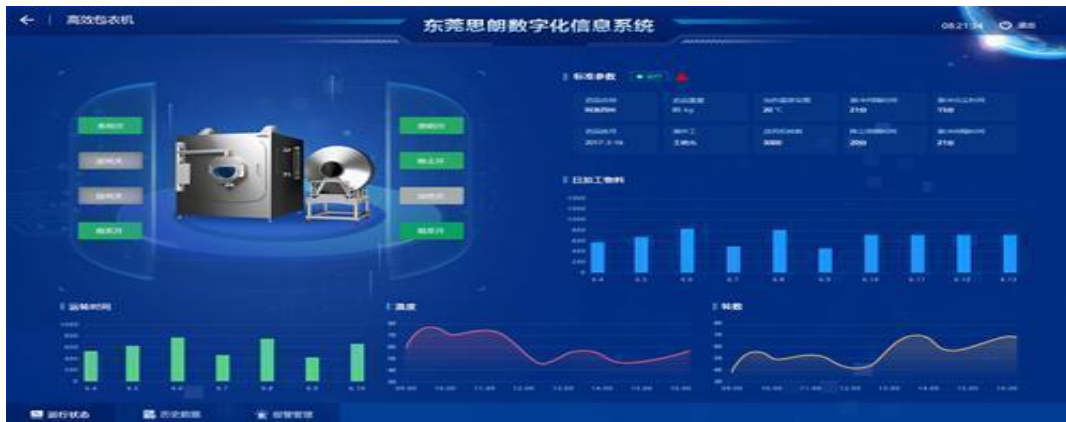

Dongguan Silang  
Digital solid factory



Digital management platform of solid preparation of  
National Innovation Center



# Market - Domestic (weak current integration)

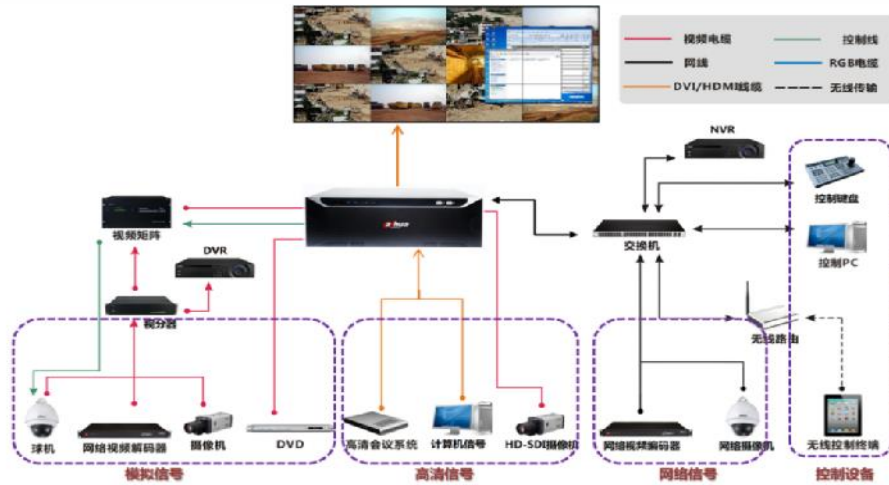

1 综治中心建设内容		
2 一、指挥大屏		
3 序号	名称	参数
4 1	室内小间距	像素间距1.579 mm 像素组成1R1G1B LED类型SMD1010 显示亮度600-800-1100(可调)
5 2	显示屏独立主控	1) 一路DVI视频输入 2) 一路音频输入 3) 四个网口输出或四路光纤输出 4) RS232接口控制, 可级联多台进行统一控制 产品功耗功率300W-1150W/1000-1300W
6 3	LED屏体增加	LED专用钢结构费用及钢架施工费用
7 4	配电箱	LED专用配电箱 (20KW, 带漏电保护)
8 5	显示工程线缆	提供配电柜到屏幕的强电线, 控制器到屏体信号线

- 1 支持语音、文本两种通知模式
- 2 支持实时、定时、周期性的通知模式
- 3 支持自定义区域分组通知模式
- 4 支持小程序、短信、IP话筒等多种发送手段
- 5 支持对通知内容和设备运行状态实时监控

支持8路模拟标清或80路高清信号交换能力;  
支持4路高清输出;  
支持8200万像素点;  
支持3840\*2160@30fps/160路1080p@30fps  
支持H.265编码能力;  
支持信号同时接入(BNC/VGA/RGB/DVI/HD-  
:VI/网络);  
支持信号多种格式无损输出, 最高分辨率达到  
4096Hz;  
支持大屏组合;支持网络远程控制, 网络键盘、模  
块  
支持Mac、Windows、Android、IOS等终端  
支持2.4G和5G双频协议, 让手机传屏的同时  
, 分享上网两不误;  
支持: 支持8个终端同时接入, 双画面同屏显

Yichun Government Comprehensive Management Center Project

# Market - Global Strategy

Global market layout

Participate in the world's top exhibitions





## Market- Customer (International-Korea&Japan)

---



- ✓ S-ONE KOREA CO., LTD, lab coaters
- ✓ EREBON CO., LTD, lab HSM
- ✓ Btresources, lifter
- ✓ Alico, lab HSM and cone mill
- ✓ CELLFA, many set lab HSM, cone mill, extruder, spheronizator



# Market- Customer (International-Russia)



# Market- Customer (International-Belarus&CIS)



**БЕЛАГРОГЕН**



# Market- Customer (International)



Your *partner* for  
pharma  
*success*



Unia Europejska  
Europejski Fundusz  
Rozwoju Regionalnego



第一药品有限公司  
PRIME PHARMACEUTICAL SDN BHD





## Market - Cases (International)



Morocco granulation line OEB4 (120kg)

# Market - Cases (International)



Canada OEB4 case



## Market - Cases (International)



Canada coater



# Market - Cases (International)



The USA



Russia



Pakistan



Serbia



Indonesia



Vietnam

## Market - Services

---

- Process service
- Design service
- Installation and commissioning service
- Training and verification services
- Daily maintenance and accessories service
- Full life cycle management service





04

## Development Plan



# 智慧固体

Wonsen  
智能工厂的践行者

- ✓ 数字化解决方案
- ✓ 工业4.0领导者



包衣机  
全自动提升混合机  
沸腾干燥机  
提升整粒机  
全自动料斗清洗机  
湿法制粒机  
配料系统  
信息系统中控室  
料桶中转区  
解包平台

- 人工智能之  
无人工厂
- 大数据分析之  
生产与决策的合理化
- 集成化工厂之  
生产方式的智慧互联
- 物联网技术之  
工厂内部和企业生态系统的全面互联

Intelligent solid turnkey solution

## 智慧粉体

- ✓ 数字化解决方案
- ✓ 工业4.0领导者

Wonsen



人工智能之  
无人工厂



大数据分析之  
生产与决策的合理化



集成化工厂之  
生产方式的智慧互联



物联网技术之  
工厂内部和企业生态系统的全面互联

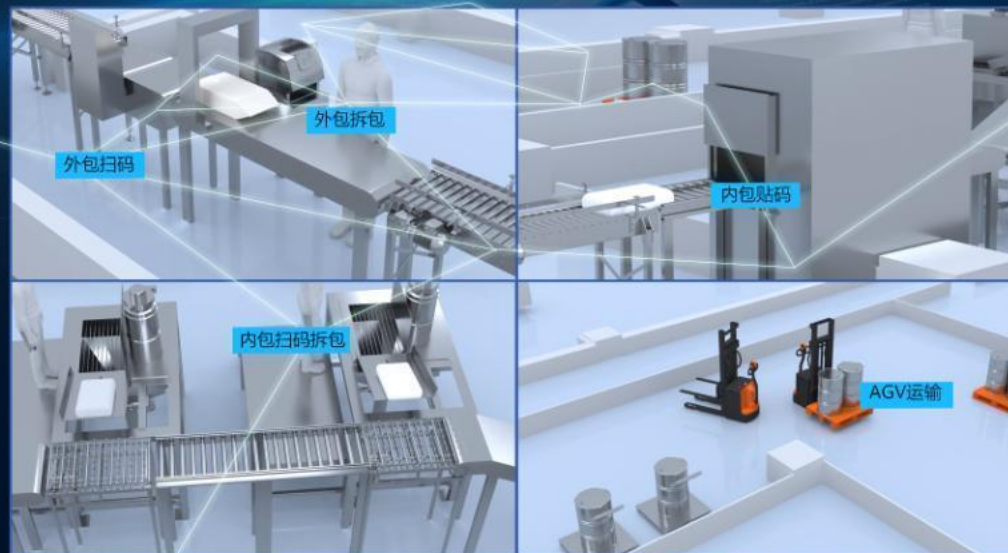

Intelligent powder turnkey solution

# Planning - Digital factory







Enjoy a video

---

Thank you

